

INLINE HIGH FLOW BIG WHITE™ HOUSINGS

Jumbo 10" and 20"

APPLICATION

For domestic applications for filtering Tank, Bore, well or town supply

DESIGN FEATURES

- The US Water Products Big White™ are manufactured with food grade reinforced polypropylene
- With slightly thicker walls and more reinforcing strips, the Big White can handle more pressure than the Big Blue series.
- All have pressure relief buttons.

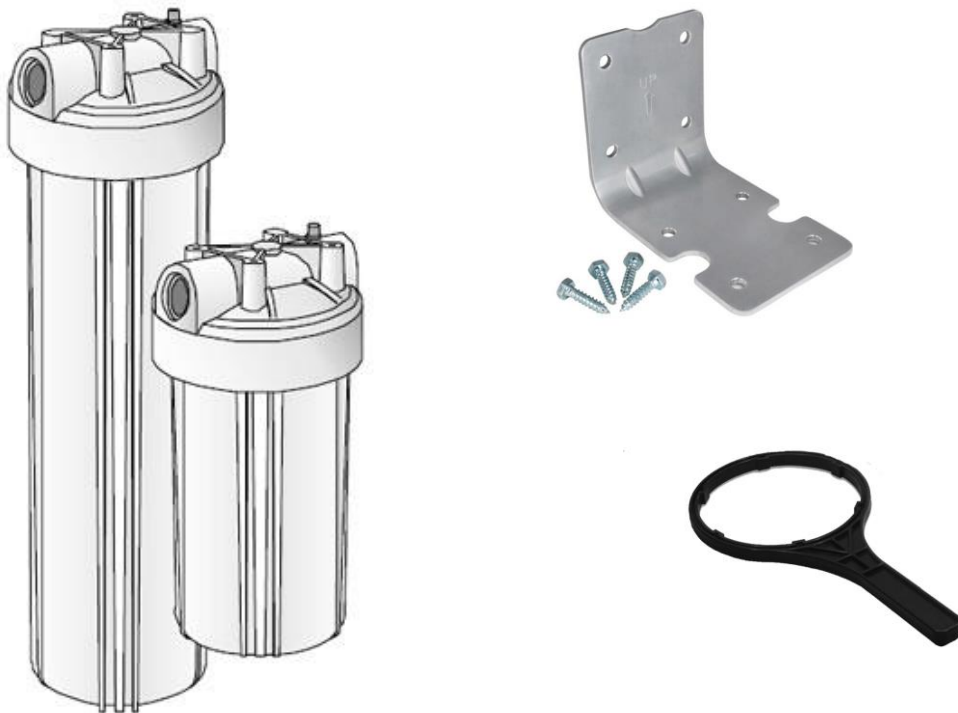

TECHNICAL DATA

Normal Operating Maximum Pressure	900kPa (125psi)
Normal Operating Temperature	50°C
Maximum Flow Rate 10" 25mm Ports	75 lpm
Maximum Flow Rate 20" 25mm Ports	150 lpm
40mm (1 ½") Ports will increase Maximum flow by 25% (optional)	
All Big White Jumbo Filters are Boxed and Include S/Steel Brkt, Screws & Spanner	