

PRESSURE TANKS FIXED MEMBRANE TYPE

For storage of water under pressure

APPLICATION

For storage of water under pressure, pressurisation systems pressure booster sets and wet tank replacement

DESIGN FEATURES

- Tank deep drawn steel shell for extra strength with epoxy enamel paint
- Fixed membrane diaphragm
 - Never stretches or creases
 - No bubbles or corners to trap sediment



TECHNICAL DATA

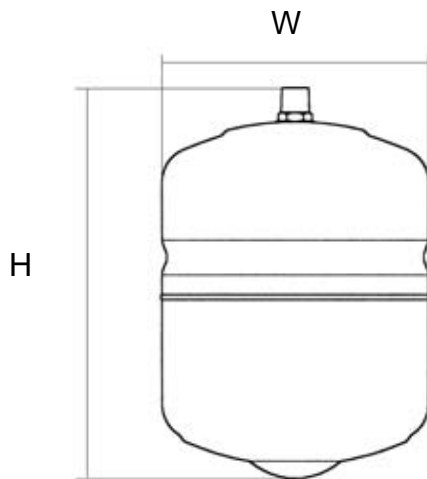

DT2/24

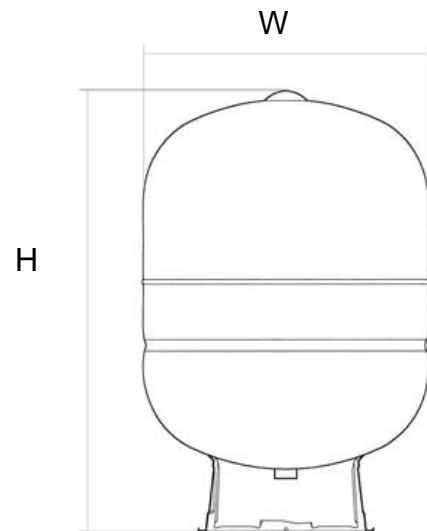

DT50/80

Part No	Capacity	Connection	Air Pre-Charge	Max Working Pressure
DT2	2 Litres	25mm BSPm	300kPa	1000kPa
DT8	8 Litres	25mm BSPm	300kPa	1000kPa
DT24	24 Litres	25mm BSPm	300kPa	1000kPa
DT50	58 Litres	25mm BSPm	300kPa	1000kPa
DT80	80 Litres	25mm BSPm	300kPa	1000kPa

Part No	Physical Dimension	Packaged Dimension
DT2	W 140mm x H 220mm	150mm x 150mm x 240mm
DT8	W 202mm x H 310mm	210mm x 210mm x 330mm
DT24	W 320mm x H 380mm	330mm x 330mm x 400mm
DT50	W 400mm x H 608mm	410mm x 410mm x 620mm
DT80	W 400mm x H 685mm	410mm x 410mm x 720mm